

DENON

DJ MIXER

DN-X400

OPERATING INSTRUCTIONS
BEDIENUNGSANLEITUNG

MODE D'EMPLOI

INSTRUCCIONES DE OPERACION

GEBRUIKSAANWIJZING
BRUKSANVISNING

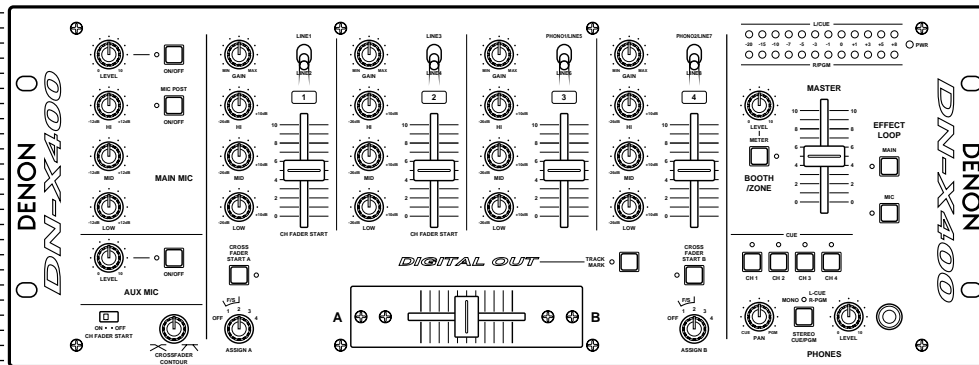

FOR ENGLISH READERS	PAGE	5 ~ PAGE	9
FÜR DEUTSCHE LESER	SEITE	10 ~ SEITE	14
POUR LES LECTEURS FRANCAIS	PAGE	15 ~ PAGE	19
PARA LECTORES DE ESPAÑOL	PAGINA	20 ~ PAGINA	24
VOOR NEDERLANDSTALIGE LEZERS	PAGINA	25 ~ PAGINA	29
FOR SVENSKA LÄSARE	SIDA	30 ~ SIDA	34



CAUTION
RISK OF ELECTRIC SHOCK
DO NOT OPEN



CAUTION: TO REDUCE THE RISK OF ELECTRIC SHOCK, DO NOT REMOVE COVER (OR BACK). NO USER SERVICEABLE PARTS INSIDE. REFER SERVICING TO QUALIFIED SERVICE PERSONNEL.



The lightning flash with arrowhead symbol, within an equilateral triangle, is intended to alert the user to the presence of uninsulated "dangerous voltage" within the product's enclosure that may be of sufficient magnitude to constitute a risk of electric shock to persons.



The exclamation point within an equilateral triangle is intended to alert the user to the presence of important operating and maintenance (servicing) instructions in the literature accompanying the appliance.

WARNING: TO PREVENT FIRE OR SHOCK HAZARD, DO NOT EXPOSE THIS APPLIANCE TO RAIN OR MOISTURE.

CAUTION:

1. Handle the power supply cord carefully

Do not damage or deform the power supply cord. If it is damaged or deformed, it may cause electric shock or malfunction when used. When removing from wall outlet, be sure to remove by holding the plug attachment and not by pulling the cord.

2. Do not open the top cover

In order to prevent electric shock, do not open the top cover. If problems occur, contact your DENON dealer.

3. Do not place anything inside

Do not place metal objects or spill liquid inside the DJ mixer. Electric shock or malfunction may result.

Please, record and retain the Model name and serial number of your set shown on the rating label.

Model No. DN-X400 Serial No. _____

LABELS:

This device complies with Part 15 of the FCC Rules. Operation is subject to the following two conditions: (1) This device may not cause harmful interference, and (2) this device must accept any interference received, including interference that may cause undesired operation.

This Class A digital apparatus meets all requirements of the Canadian Interference-Causing Equipment Regulations.

Cet appareil numérique de la classe A respecte toutes les exigences du Règlement sur le matériel brouilleur du Canada.

CAUTION

TO PREVENT ELECTRIC SHOCK, MATCH WIDE BLADE OF PLUG TO WIDE SLOT, FULLY INSERT.

ATTENTION







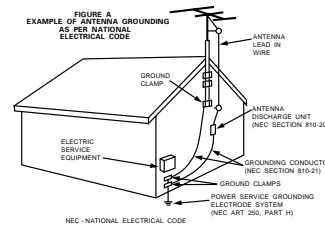

POUR ÉVITER LES CHOCS ÉLECTRIQUES, INTERDUIRE LA LAME LA PLUS LARGE DE LA FICHE DANS LA BORNE CORRESPONDANTE DE LA PRISE ET POUSSER JUSQU' AU FOND.

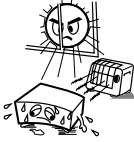
SAFETY INSTRUCTIONS

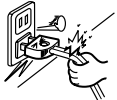
1. Read Instructions – All the safety and operating instructions should be read before the appliance is operated.
2. Retain Instructions – The safety and operating instructions should be retained for future reference.
3. Heed Warnings – All warnings on the appliance and in the operating instructions should be adhered to.
4. Follow Instructions – All operating and use instructions should be followed.
5. Water and Moisture – The appliance should not be used near water – for example, near a bathtub, washbowl, kitchen sink, laundry tub, in a wet basement, or near a swimming pool, and the like.
6. Carts and Stands – The appliance should be used only with a cart or stand that is recommended by the manufacturer.
- 6A. An appliance and cart combination should be moved with care. Quick stops, excessive force, and uneven surfaces may cause the appliance and cart combination to overturn.
7. Wall or Ceiling Mounting – The appliance should be mounted to a wall or ceiling only as recommended by the manufacturer.
8. Ventilation – The appliance should be situated so that its location or position does not interfere with its proper ventilation. For example, the appliance should not be situated on a bed, sofa, rug, or similar surface that may block the ventilation openings; or, placed in a built-in installation, such as a bookcase or cabinet that may impede the flow of air through the ventilation openings.
9. Heat – The appliance should be situated away from heat sources such as radiators, heat registers, stoves, or other appliances (including amplifiers) that produce heat.
10. Power Sources – The appliance should be connected to a power supply only of the type described in the operating instructions or as marked on the appliance.
11. Grounding or Polarization – Precautions should be taken so that the grounding or polarization means of an appliance is not defeated.
12. Power-Cord Protection – Power-supply cords should be routed so that they are not likely to be walked on or pinched by items placed upon or against them, paying particular attention to cords at plugs, convenience receptacles, and the point where they exit from the appliance.
14. Cleaning – The appliance should be cleaned only as recommended by the manufacturer.
15. Power Lines – An outdoor antenna should be located away from power lines.
16. Outdoor Antenna Grounding – If an outside antenna is connected to the receiver, be sure the antenna system is grounded so as to provide some protection against voltage surges and built-up static charges. Article 810 of the National Electrical Code, ANSI/NFPA 70, provides information with regard to proper grounding of the mast and supporting structure, grounding of the lead-in wire to an antenna-discharge unit, size of grounding conductors, location of antenna-discharge unit, connection to grounding electrodes, and requirements for the grounding electrode. See Figure A.
17. Nonuse Periods – The power cord of the appliance should be unplugged from the outlet when left unused for a long period of time.
18. Object and Liquid Entry – Care should be taken so that objects do not fall and liquids are not spilled into the enclosure through openings.
19. Damage Requiring Service – The appliance should be serviced by qualified service personnel when:
 - A. The power-supply cord or the plug has been damaged; or
 - B. Objects have fallen, or liquid has been spilled into the appliance; or
 - C. The appliance has been exposed to rain; or
 - D. The appliance does not appear to operate normally or exhibits a marked change in performance; or
 - E. The appliance has been dropped, or the enclosure damaged.
20. Servicing – The user should not attempt to service the appliance beyond that described in the operating instructions. All other servicing should be referred to qualified service personnel.



**NOTE ON USE / HINWEISE ZUM GEBRAUCH /
OBSERVATIONS RELATIVES A L'UTILISATION / NOTAS SOBRE EL USO /
ALVORENS TE GEBRUIKEN / OBSERVERA**

 <ul style="list-style-type: none"> Avoid high temperatures. Allow for sufficient heat dispersion when installed on a rack. Vermeiden Sie hohe Temperaturen. Beachten Sie, daß eine ausreichend Luftzirkulation gewährleistet wird, wenn das Gerät auf ein Regal gestellt wird. Eviter des températures élevées. Tenir compte d'une dispersion de chaleur suffisante lors de l'installation sur une étagère. Evite altas temperaturas. Permite la suficiente dispersión del calor cuando está instalado en la consola. Vermijd hoge temperaturen. Zorg voor een degelijk hitteafvoer indien het apparaat op een rek wordt geplaatst. Undvik höga temperaturer. Se till att det finns möjlighet till god värmeavledning vid montering i ett rack. 	 <ul style="list-style-type: none"> Keep the set free from moisture, water, and dust. Halten Sie das Gerät von Feuchtigkeit, Wasser und Staub fern. Protéger l'appareil contre l'humidité, l'eau et poussière. Mantenga el equipo libre de humedad, agua y polvo. Laat geen vochtigheid, water of stof in het apparaat binnendringen. Utsätt inte apparaten för fukt, vatten och damm. 	 <ul style="list-style-type: none"> Do not let foreign objects in the set. Keine fremden Gegenstände in das Gerät kommen lassen. Ne pas laisser des objets étrangers dans l'appareil. No deje objetos extraños dentro del equipo. Laat geen vreemde voorwerpen in dit apparaat vallen. Se till att främmande föremål inte tränger in i apparaten.
 <ul style="list-style-type: none"> Handle the power cord carefully. Hold the plug when unplugging the cord. Gehen Sie vorsichtig mit dem Netzkabel um. Halten Sie das Kabel am Stecker, wenn Sie den Stecker herausziehen. Manipuler le cordon d'alimentation avec précaution. Tenir la prise lors du débranchement du cordon. Maneje el cordón de energía con cuidado. Sostenga el enchufe cuando desconecte el cordón de energía. Hanteer het netsnoer voorzichtig. Houd het snoer bij de stekker vast wanneer deze moet worden aan- of losgekoppeld. Hantera nätkablen varsamt. Håll i kablenn när den kopplas från el-uttaget. 	 <ul style="list-style-type: none"> Unplug the power cord when not using the set for long periods of time. Wenn das Gerät eine längere Zeit nicht verwendet werden soll, trennen Sie das Netzkabel vom Netzstecker. Débrancher le cordon d'alimentation lorsque l'appareil n'est pas utilisé pendant de longues périodes. Desconecte el cordón de energía cuando no utilice el equipo por mucho tiempo. Neem altijd het netsnoer uit het stopkontakt wanneer het apparaat gedurende een lange periode niet wordt gebruikt. Koppla ur nätkablenn om apparaten inte kommer att användas i lång tid. 	 <ul style="list-style-type: none"> Do not let insecticides, benzene, and thinner come in contact with the set. Lassen Sie das Gerät nicht mit Insektiziden, Benzin oder Verdünnungsmitteln in Berührung kommen. Ne pas mettre en contact des insecticides, du benzène et un diluant avec l'appareil. No permita el contacto de insecticidas, gasolina y diluyentes con el equipo. Laat geen insectenverdelgende middelen, benzine of verfverdunder met dit apparaat in contact komen. Se till att inte insektsmedel på spraybruk, bensin och thinner kommer i kontakt med apparatens hölje.
 <ul style="list-style-type: none"> Handle the power cord carefully. Hold the plug when unplugging the cord. Gehen Sie vorsichtig mit dem Netzkabel um. Halten Sie das Kabel am Stecker, wenn Sie den Stecker herausziehen. Manipuler le cordon d'alimentation avec précaution. Tenir la prise lors du débranchement du cordon. Maneje el cordón de energía con cuidado. Sostenga el enchufe cuando desconecte el cordón de energía. Hanteer het netsnoer voorzichtig. Houd het snoer bij de stekker vast wanneer deze moet worden aan- of losgekoppeld. Hantera nätkablen varsamt. Håll i kablenn när den kopplas från el-uttaget. 	 <p>* (For sets with ventilation holes)</p> <ul style="list-style-type: none"> Do not obstruct the ventilation holes. Die Belüftungsöffnungen dürfen nicht verdeckt werden. Ne pas obstruer les trous d'aération. No obstruya los orificios de ventilación. De ventilatieopeningen mogen niet worden geblokkeerd. Täpp inte till ventilationsöppningarna. 	 <ul style="list-style-type: none"> Never disassemble or modify the set in any way. Versuchen Sie niemals das Gerät auseinander zu nehmen oder auf jegliche Art zu verändern. Ne jamais démonter ou modifier l'appareil d'une manière ou d'une autre. Nunca desarme o modifique el equipo de ninguna manera. Nooit dit apparaat demonteren of op andere wijze modifieren. Ta inte isär apparaten och försök inte bygga om den.

**FRONT PANEL DIAGRAM / VORDERES BEDIENFELD-SCHEMA /
SCHEMA DU PANNEAU AVANT / DIAGRAMA DEL PANEL FRONTAL /
OVERZICHT VAN VOORPANEEL / FRONTPANELEN**

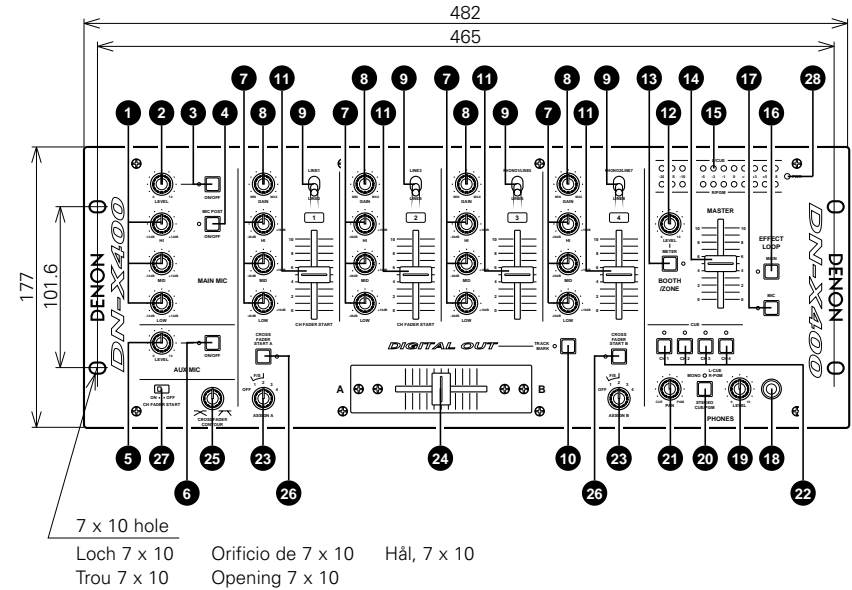

**REAR PANEL DIAGRAM / HINTERES ANSCHLUSSFELD-SCHEMA /
SCHEMA DU PANNEAU ARRIERE / DIAGRAMA DEL PANEL POSTERIOR /
OVERZICHT VAN ACHTERPANEEL / BAKPANELEN**

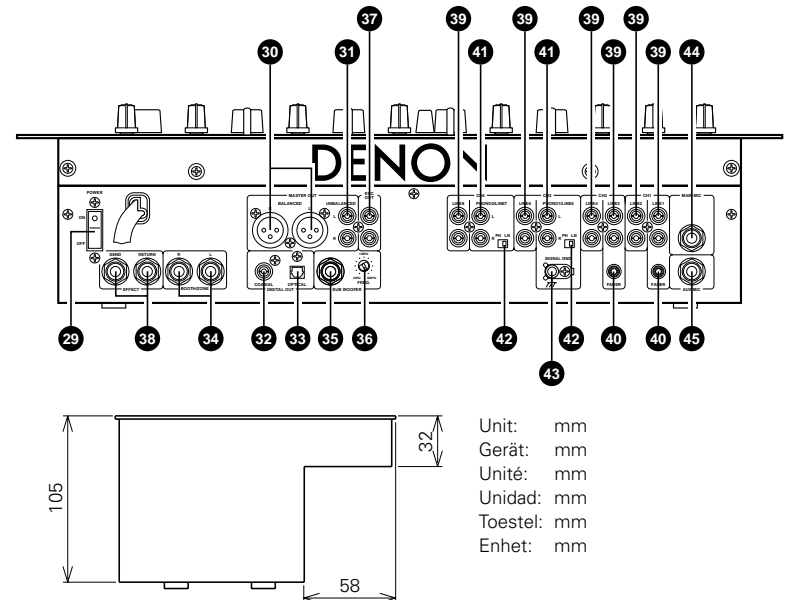

CAUTION

- The ventilation should not be impeded by covering the ventilation openings with items, such as newspapers, table-cloths, curtains, etc.
- No naked flame sources, such as lighted candles, should be placed on the apparatus.
- Please be care the environmental aspects of battery disposal.
- The apparatus shall not be exposed to dripping or splashing for use.
- No objects filled with liquids, such as vases, shall be placed on the apparatus.

• **DECLARATION OF CONFORMITY**

We declare under our sole responsibility that this product, to which this declaration relates, is in conformity with the following standards:

EN60065, EN55013, EN55020, EN61000-3-2 and EN61000-3-3.

Following the provisions of 73/23/EEC, 89/336/EEC and 93/68/EEC Directive.

• **ÜBEREINSTIMMUNGSERKLÄRUNG**

Wir erklären unter unserer Verantwortung, daß dieses Produkt, auf das sich diese Erklärung bezieht, den folgenden Standards entspricht:

EN60065, EN55013, EN55020, EN61000-3-2 und EN61000-3-3.

Entspricht den Verordnungen der Direktive 73/23/EEC, 89/336/EEC und 93/68/EEC.

• **DECLARATION DE CONFORMITE**

Nous déclarons sous notre seule responsabilité que l'appareil, auquel se réfère cette déclaration, est conforme aux standards suivants:

EN60065, EN55013, EN55020, EN61000-3-2 et EN61000-3-3.

D'après les dispositions de la Directive 73/23/EEC, 89/336/EEC et 93/68/EEC.

• **DECLARACIÓN DE CONFORMIDAD**

Declaramos bajo nuestra exclusiva responsabilidad que este producto al que hace referencia esta declaración, está conforme con los siguientes estándares:

EN60065, EN55013, EN55020, EN61000-3-2 y EN61000-3-3.

Siguiendo las provisiones de las Directivas 73/23/EEC, 89/336/EEC y 93/68/EEC.

• **EENVORMIGHEIDSVERKLARING**

Wij verklaren uitsluitend op onze verantwoordelijkheid dat dit produkt, waarop deze verklaring betrekking heeft, in overeenstemming is met de volgende normen:

EN60065, EN55013, EN55020, EN61000-3-2 en EN61000-3-3.

Volgens de bepalingen van de Richtlijnen 73/23/EEC, 89/336/EEC en 93/68/EEC.

• **ÖVERENSSTÄMMELSESINTYG**

Härmed intygas helt på eget ansvar att denna produkt, vilken detta intyg avser, uppfyller följande standarder:

EN60065, EN55013, EN55020, EN61000-3-2 och EN61000-3-3.

Enligt stadgarna i direktiv 73/23/EEC, 89/336/EEC och 93/68/EEC.

– TABLE OF CONTENTS –

1 Main features5	6 Track mark9
2 Installation5	7 PFL (Pre Fader Level)9
3 Part names and functions5, 6	8 Replacing the crossfader9
4 Connections.....7	9 Specifications9
5 Fader start8	

• ACCESSORIES

Please check to make sure the following items are included with the main unit in the carton:

- | | |
|---------------------------------|---|
| ① Operating instructions1 | ② Connection cords (3.5 mm stereo mini cord)2 |
|---------------------------------|---|

1 MAIN FEATURES

CONGRATULATIONS! You have purchased the DENON DN-X400 DJ mixer from DENON.

1. CH. Fader and Crossfader start

The CD player can be started or stopped simply by increasing or decreasing the level of the CH fader or by using the cross fader left to right or right to left. (This function can only be used when the DENON CD players DN-1800F, DN-2100F or DN-2600F is connected to the DN-X400.)

2. Digital outputs

The DN-X400 allows you to record directly to CD-R, MiniDisc or a hard disk device through it's exclusive coaxial and optical digital outputs. The digital outputs maintains a constant 16 bit / 44.1 kHz signal.

3. Track mark

Track numbers can be added at any position during recording onto a digital recorder using the DN-X400's digital outputs.

4. Enhanced input/output terminals (Analog)

8 Line, 2 Phono, 2 microphone systems, 2 Main outputs, Booth/Zone output, Sub woofer output and Rec output are provided independently. Effect in/out terminals are also provided for a external effects processor.

5. 3-Band equalizer/Gain

Bass, Mid, Treble and Gain controls are available on every input channel.

6. Crossfader contour

This feature allows adjusting the "shape" of the Crossfader response from a gentle curve for smooth, long running fades, to the steep pitch required for top performance cut and scratch effects.

7. Mic post

This feature will pass the Main Mic signal into the Booth/Zone, Rec output and Digital output signal path. In the OFF mode, the Main Mic signal will not be routed through the above outputs.

8. PFL (Pre Fader Level)

This feature provides a means to adjust the input level gain of each channel to avoid over loading. By making this adjustment in advance will insure a smooth transition between cross fades or channel fades.

3 PART NAMES AND FUNCTIONS

(1) Front Panel

1 MAIN MIC EQ controls

• Contour the frequency response of the Main Mic input -12 dB to +12 dB.

HI

• Adjusts high-tone Main Mic sound -12 dB to +12 dB. At the center position, sound is flat.

MID

• Adjusts mid-tone Main Mic sound -12 dB to +12 dB. At the center position, sound is flat.

LOW

• Adjusts low-tone Main Mic sound -12 dB to +12 dB. At the center position, sound is flat.

2 MAIN MIC level control

• Adjusts the level of the Main Mic input.

3 MAIN MIC ON/OFF button

• Puts the Main Mic signal into the Main outputs signal path.
• When the button is pressed, the Main Mic is on and the adjacent orange indicator lights.

4 MIC POST ON/OFF button

• Puts the Main Mic signal into the Booth/Zone, Rec and Digital out signal path.
• When the button is pressed, the adjacent green indicator lights.

5 AUX MIC level control

• Adjusts the level of the Aux Mic input.

6 AUX MIC ON/OFF button

• Puts the Aux Mic signal into the mixer signal path.
• When the button is pressed, the Aux Mic is on and the adjacent orange indicator lights.

7 Source EQ controls

• Contour the frequency response of the selected inputs.

HI

• Adjusts the high-tone sound -26 dB to +10 dB. At the center position, sound is flat.

MID

• Adjusts the mid-tone sound -26 dB to +10 dB. At the center position, sound is flat.

LOW

• Adjusts the low-tone sound -26 dB to +10 dB. At the center position, sound is flat.

NOTE:

Clipping may occur if adjustments are set to harsh.

8 GAIN level control

• Adjusts the level of the selected input ∞ to +10 dB.

9 Source input select switch

• Selects either a Phono/Line or Line input for the source.

10 TRACK MARK button

• The track number is switched when this button is pressed during recording onto a digital recorder using the digital outputs.

11 Source input fader (Ch. fader)

• Controls the level of the selected Input.

12 BOOTH/ZONE level control

• Adjusts the level of the Booth/Zone outputs.

13 BOOTH/ZONE METER button

• When this button is pressed down and held, the meter indicates the stereo level in the LEFT and RIGHT meter output. The adjacent green indicator lights.

14 MASTER LEVEL fader

• Adjusts the level of the Main outputs. Signals from the channels selected with the Assign switches will be output using the Source input fader (Ch. fader) and the Crossfader, while signals from other channels will be outputs using the Source input fader (Ch. fader).

15 Peak dB CUE/PROGRAM meter

• Displays the output level following Master Level adjustment, the peak level is held for 1 second. Display range : -20 dB to +8 dB.
• Can switch between two display mode. See below 20.

16 EFFECT LOOP MAIN button

• Routes the Main signal through the external processor attached to the EFFECT connectors on the rear.
• When the button is pressed in, the adjacent orange indicator lights. (When the processor isn't attached, indicator blinks.)

17 EFFECT LOOP MIC button

• Routes the Main Mic signal through the external processor attached to the EFFECT connectors on the rear.
• When the button is pressed in, the adjacent orange indicator lights. (When the processor isn't attached, indicator blinks.)

NOTE:

When the Effect Loop Main and Mic are on, the signal of Mic is output to all the outputs regardless of setting the Main Mic and the Post Mic.

18 HEADPHONE output jack

• Accepts 1/4" stereo headphone plugs.

19 HEADPHONE level control

• Adjusts the volume for the headphones.

2 INSTALLATION

When the DN-X400 is mounted inside a coffin or DJ booth, we recommend leaving a 3 cm blank space above the mixer if possible.

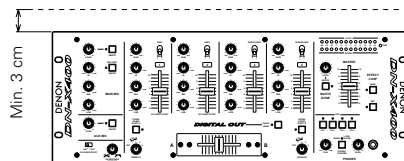

20 HEADPHONE mode button

- In the STEREO mode, this button feeds STEREO Program and Cue to both earcups, in the MONO mode, the Headphone circuit provides MONO Cue to the left ear and MONO Program to the right.
- In the STEREO mode, the meter indicates the stereo level in the LEFT and RIGHT Main Outputs. In the MONO mode, mono CUE level is displayed on the Left meter and mono PROGRAM level is displayed on the Right meter.
- In the MONO mode, the adjacent green indicator lights.

21 HEADPHONE PAN control

- Serves two purposes...In the STEREO mode it changes the relative levels of the Cue and Program mixed together in both earcups. In the MONO mode it changes the balance between the Mono Cue in the left ear cup and the Mono Program in the right.

22 CUE buttons

- Pressing in any or all of the CUE buttons routes the respective Source to the Headphone and Meter Cue sections. Pressing multiple buttons makes it possible to derive mixed sound from the selected sources. The adjacent red indicator illuminates when the button is depressed.

23 CROSSFADE ASSIGN A, B switches

- Assigns the Crossfader to any of the four Input Channels and Off.

OFF

Select when not using the crossfader.

1 to 4

Select what channels (CH-1 to CH-4) to assign to A and B.
Channels not assigned to A or B are output without passing through the crossfader.

24 CROSSFADER

- Controls the relative output level from the summed A and B Mixes. When the fader is at its far left, only the A Mix is heard from the Outputs. As the fader is moved toward the right, the amount of B Mix is increased and the amount of A Mix is decreased. When the fader is centered, equal amounts of A and B Mixes are routed to the Outputs. Fully right is all B Mix at the Outputs.

25 CROSSFADER CONTOUR control

- Allows adjusting the "shape" of the Crossfader response from a gentle curve for smooth, long running fades, to the steep pitch required for top performance cut and scratch effects.

26 CROSSFADER START A, B buttons

- The function to start the performance of CD Player with Crossfader automatically is turned on/off.
- When the button is pressed in, the Crossfader Start is on and the adjacent orange indicator lights.

27 CH. FADER START switches

- This function will start the performance of CD Player with Ch. fader automatically is turned on/off.

28 POWER indicator

- When the green indicator is lit, the DN-X400 is ready to go.

(2) Rear Panel**29 POWER switch**

- Press the switch to turn the power on.

30 MAIN OUT (BALANCED) connectors

- These XLR type connectors provide a balanced line level output.
- Connect these connectors to the balanced analog input connectors on an amplifier or console.
- Pin layout 1. Common 2. Hot 3. Cold
- Applicable connector:
Cannon XLR-3-31 or equivalent.

NOTE:

Do not short-circuit the hot or cold pin with the common pin.

31 MAIN OUT (UNBALANCED) jacks

- This stereo pair of RCA jacks provide a unbalanced line level output.
- Connect these jacks to the unbalanced analog input jacks on an amplifier or console.

32 DIGITAL OUT (COAXIAL) jack

- These RCA jacks provide a digital output data. The signal is unaffected by the Master Level fader.
- We recommend using a 75Ω/ohm RCA cord for best digital transfer. (available from any audio/video retailer)

33 DIGITAL OUT (OPTICAL) jack

- The signal is unaffected by the Master Level fader.

34 BOOTH/ZONE OUT jacks

- These 1/4" jacks provide a balanced line level output with independent front panel Booth/Zone Level controls and are not affected by the Master Level control.
- Connect these jacks to the balanced analog input jacks on an amplifier or console.

35 SUBWOOFER output jack

- This 1/4" mono jacks provide a mono line level output of Main Out. The signal is affected by the Master Level fader.
- Connect this jacks to the subwoofer input jack on an amplifier.

36 SUBWOOFER frequency control

- Adjusts the cut off frequency of the low pass filter 40 Hz to 200 Hz.
- The low adjustment, will effect the Subwoofer output.

37 REC OUT jacks

- This stereo pair of RCA jacks provide a line level output. The signal is unaffected by the Master Level fader.
- It is intended for use with a tape recorder, but is not restricted to that purpose.

38 EFFECT jacks

- These 1/4" stereo jacks allow stereo external processing of the Program signal.
- These are switching jacks — always complete the loop when connecting a send and return, or no sound will be heard.

39 LINE 1, 2, 3, 4, 6, 8 input jacks

- These stereo pairs of unbalanced RCA jacks are Inputs for any line level device.

40 Ch 1, 2 FADER output jacks

- Connect these jacks to the Fader input jacks of the DN-1800F, the DN-2100F and the DN-2600F using the 3.5 mm stereo mini cord.

41 PHONO 1, 2 / LINE 5, 7 input jacks

- These stereo pairs of unbalanced RCA jacks are Inputs for a Phono (RIAA) stage for magnetic (MM) cartridges or a Line stage suitable for any device, such as a CD player.

42 PHONO 1, 2 / LINE 5, 7 switches

- These switches change the Input from Phono to a Line level inputs.
- These switches set a Line level inputs when Turntable is not connected.

43 Phono Ground screw

- This screws provide a place to connect the ground wire from a turntable. This terminal is exclusively for a turntable grounding and not a safety earth ground.

44 MAIN MIC input jack

- Accepts a balanced microphone with 1/4" jacks.

45 AUX MIC input jack

- Accepts a balanced microphone with 1/4" jacks.

4 CONNECTIONS

Refer to the Connection Diagram below.

1. Make certain AC power is off while making connections.
2. Quality cables make a big difference in fidelity and punch. Use high-quality, audio cables.
3. Do not use excessively long cables. Be sure plugs and jacks are securely fastened. Loose connections cause hum, noise, or intermittents that could damage your speakers.

4. Connect all stereo input sources. Then connect any effects into the stereo Effect, if used. Connect your Microphone(s) and monitor headphones. Make sure all faders are at "zero" and the unit is off. Take care to connect only one cable at a time, pay attention to L and R position of jacks, on both the DN-X400 and outboard gear.

5. Connect the stereo outputs to the power amplifier(s) and/or tape deck(s) and/or MD recorder(s) and/or CD recorder(s). Plug the DN-X400 into AC power outlet.

NOTE:

Always switch on your audio input sources such as CD players first, then your mixer, and finally any amplifiers. When turning off, always reverse this operation by turning off amplifiers, then your mixer, and then input units.

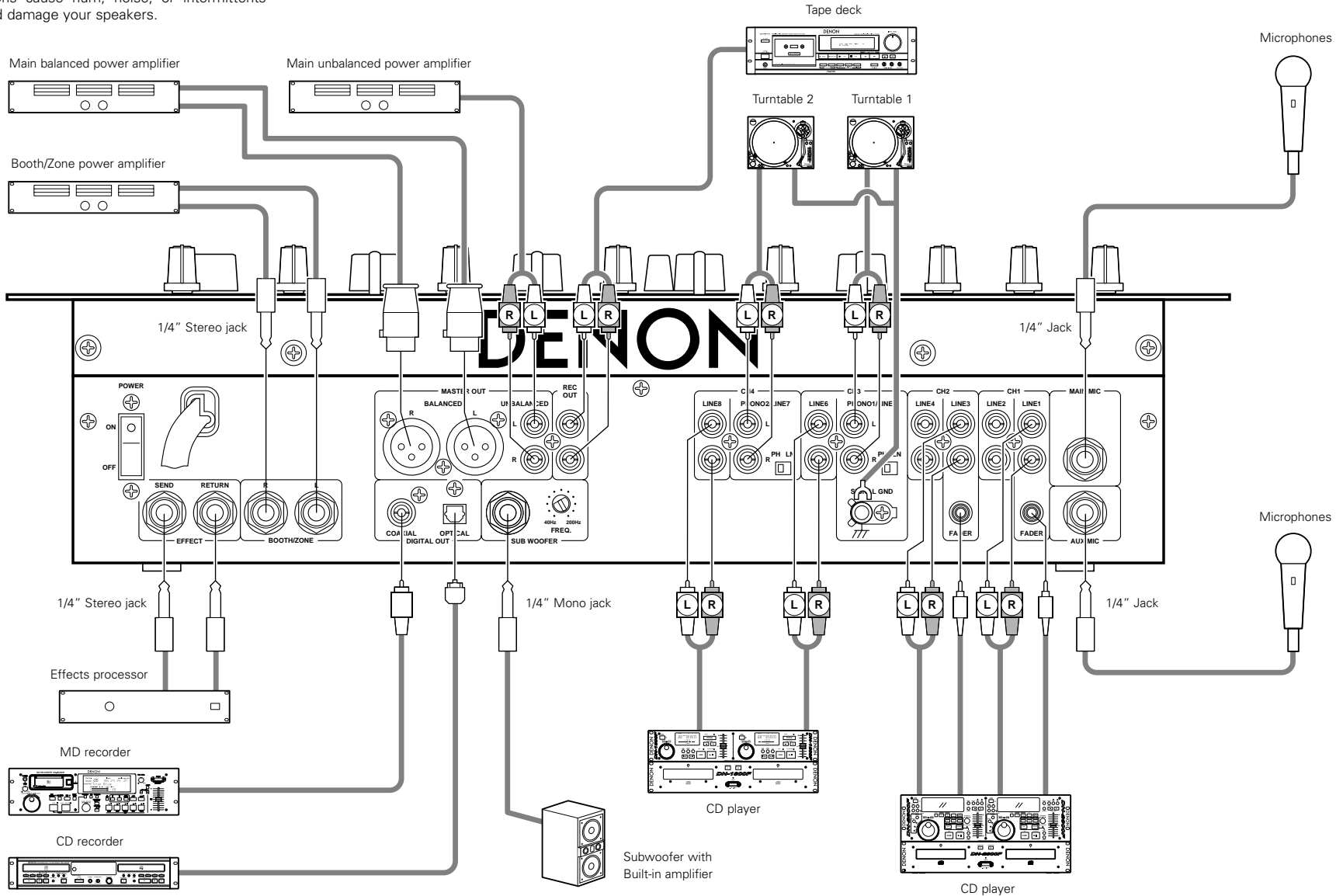

5 FADER START

If the separately sold DN-1800F, DN-2100F and DN-2600F players are connected to CH-1 or CH-2, they can be started using the source input fader (Ch. fader) or Crossfader, as long as the 3.5 mm stereo mini cords have been connected.

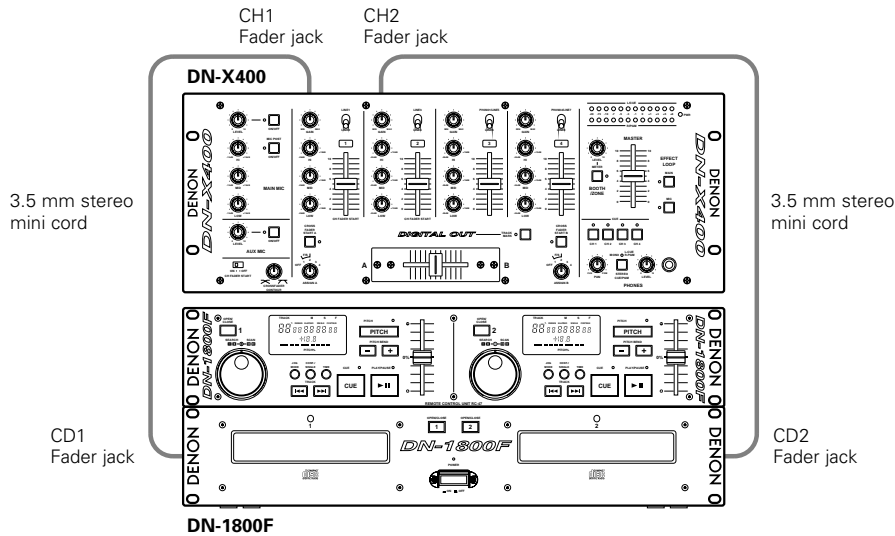

Channel Fader Start

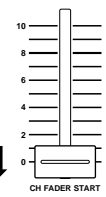
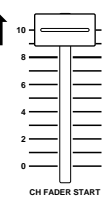
- 1 Turn on the Ch. fader start switch.
 
- 2 Move the source input fader (Ch. fader) of CH-1 or CH-2 control all the way to the bottom.
 
- 3 **DN-1800F**
Set the cue point on either drive.
DN-2100F and DN-2600F
Set the A-1 or A-2 point on either drive.
 
- 4 When you want to start the player, move up the source input fader (Ch. fader) and the CD player will begin playing.

NOTES:

- Channels selected with the Crossfader Assign A, B switches and the Crossfader Start A, B buttons cannot be started with the source input fader (Ch. fader).
- Ch. Fader Start and Cross Fader Start for the same source will not operate simultaneously. You must select from either one. If both Ch. Fader and Cross Fader switches are ON, priority will be the cross fader.

Crossfader Start

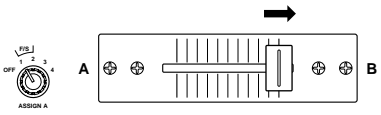
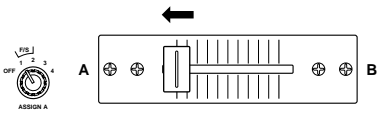
- 1 Using the Crossfader Assign A, B switches, select the channel (CH-1 or CH-2) that the CD player is connected.
- 2 Press the Crossfader Start A, B buttons of the channel connected to the CD player to be controlled.
- 3 Slide the Crossfader all the way in direction opposite the source you want to start. (In the following example, startup is done with the CD player connected to CH-1 set to Assign A.)
 
- 4 **DN-1800F**
Set the cue point on the left drive.
DN-2100F and DN-2600F
Set the A-1 or A-2 point on the left drive.
- 5 Use the Crossfader Contour control to control the cross fader startup curve.
- 6 When the Crossfader is slid in the opposite direction as in "1", CD player play will begin.
 

6 TRACK MARK

- CD category digital signals are output from the DN-X400's digital outputs. Track numbers can be added at any position during recording of these signals onto a digital recorder.
- Connect the DN-X400's digital outputs to the digital recorder. (Refer to 4 CONNECTIONS on page 7.)

1	Start recording on the digital recorder.
2	<p>Press the TRACK MARK button.</p> <ul style="list-style-type: none"> • The output signal's track number changes and the green indicator lights for 4 seconds. 

NOTE:
During the 4 seconds in which the track number is being changed, the track number cannot be changed again.

7 PFL (Pre Fader Level)

1. Press the HEADPHONE mode button.
2. Press the CUE button that you wish to monitor 1-4 (make sure your source is playing).
3. Turn the blue GAIN level knob until the L/CUE (top) meters peak at the 0 dB level.
4. Perform your mix using the cross fader or channel fader at your desire.

NOTES:

- For proper operation, your channel levels should always be set to or left on reference line 8.
- This adjustment can be made even if the channel fader is set to zero level.

8 REPLACING THE CROSSFADER

The Crossfader may be removed without any disassembly of the DN-X400 itself.

1. Remove the two (A) outer screws attaching the crossfader assembly to the front panel.
2. Pull the Crossfader Assembly forward and unplug the ribbon from the connector on the panel board.
3. Install the replacement assembly by reversing the above instructions.

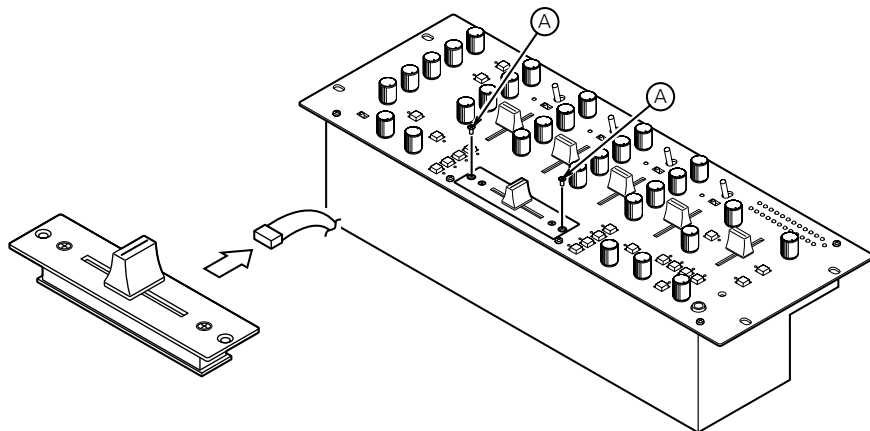

9 SPECIFICATIONS

■ **GENERAL**

Dimensions:	482 (W) x 105 (H) x 177 (D) mm (without feet)
Installation:	19-inch rack mountable 4U
Mass:	5.5 kg
Power supply:	120 V AC ±10%, 60 Hz (U. S. A. and Canada models) 230 V AC ±10%, 50 Hz (European models)
Power consumption:	26 W
Environmental conditions:	Operational temperature: 5 to 35°C (41 to 95°F) Operational humidity: 25 to 85% (no condensation) Storage temperature: -20 to 60°C (4 to 140°F)

■ **AUDIO SECTION**

Input Sensitivity & Impedance:		
Main Mic	-54 dBV (2.0 mV)	10 kΩ/kohms
Aux Mic	-60 dBV (1.0 mV)	10 kΩ/kohms
Effect (Return)	-10 dBV (316 mV)	50 kΩ/kohms
2-Phono	-50 dBV (3.0 mV)	50 kΩ/kohms
8-Line	-14 dBV (200 mV)	50 kΩ/kohms
Output level & Impedance:		
Main (Balanced)	4 dBm (1.23 V)	600 Ω/ohms load
Main (Unbalanced)	0 dBV (1.0V)	1 kΩ/kohms
Booth/Zone (Balanced)	4 dBm (1.23 V)	600 Ω/ohms load
Rec (RCA)	-10 dBV (316 mV)	1 kΩ/kohms
Effect (Send)	-10 dBV (316 mV)	1 kΩ/kohms
Subwoofer	-2 dBV (800 mV)	1 kΩ/kohms
Headphone	-4 dBV (631 mV)	150 Ω/ohms (33 Ω/ohms load)
Frequency Response:		
Line	20 to 20 kHz	±2 dB
Phono	20 to 20 kHz	RIAA ±2 dB
Mic	20 to 20 kHz	±2 dB
Signal to Noise ratio:		
Line	80 dB	0 dBm, 1 kHz, EQ flat
Phono	75 dB	0 dBm, 1 kHz, EQ flat
Main Mic	65 dB	0 dBm, 1 kHz, EQ flat
Total harmonic distortion rate:		
Line	Below 0.05%	
Phono	Below 0.05%	
Cross talk:		
	Over 70 dB	
Channel equalizer:		
Hi	+10 dB, -26 dB (13 kHz)	
Mid	+10 dB, -26 dB (1 kHz)	
Low	+10 dB, -26 dB (70 Hz)	
Microphone equalizer:		
Hi	+12 dB, -12 dB (10 kHz)	
Mid	+12 dB, -12 dB (1 kHz)	
Low	+12 dB, -12 dB (100 Hz)	
Digital output (COAXIAL):		
Signal format	IEC958 Type II	
Output level	0.5 Vp-p 75 Ω/ohms	
Output signal level	-6 dB	
Digital output (OPTICAL):		
Signal format	IEC958 Type II	

* Specifications and design are subject to change without notice for purpose of improvement.

NIPPON COLUMBIA CO., LTD.

14-14, AKASAKA 4-CHOME, MINATOKU, TOKYO 107-8011, JAPAN
Telephone: (03) 3584-8111